

---

# New kinds of literacy, and the world of visual information

by Conrad Taylor

an exploratory paper for the EIGVIL workshop, 8 September 2003<sup>1</sup>

EIGVIL workshop:  
Explanatory &  
Instructional Graphics  
and Visual Information  
Literacy  
8 September 2003  
London Metropolitan  
University

The dictionary definition of literacy is the ability to read and to write, to deal adequately with a written system of communication. As such, the teaching of literacy skills is seen as the foundation of education.

In recent decades we have also begun to hear of Visual Literacy, Media Literacy and Information Literacy. Are these metaphorical extensions of the concept of 'literacy' just a rhetorical device by peripheral fields of study to claim equality of importance with literacy skills, or do they really tell us something about the nature of understanding?

## Metaphor and its misapprehension

Metaphor is a powerful fast-track way of extending our vocabulary. However, it has dubious side-effects. The question to ask is: how many characteristics of the original meaning are we supposed to understand to be carried across to the new one?

Take an example: we hear that a *ceiling* has been placed on university admissions. Like a real ceiling, this metaphorical one imposes an inflexible limit. But we do not expect bits of plaster to fall off this ceiling, nor can we be disturbed by a loud music coming from above it. The limits of this metaphor are easy to understand by applying of common sense, made easy because the original ceiling is a concrete object.

When the idea of 'literacy' is appropriated metaphorically, it is more difficult to analyse its limits of application in the new context. In part, this is because Literacy is an abstract noun, and different people may have different senses of the the 'edges' of this concept. While some people feel that better understanding can be achieved by agreeing sharp edges for such concepts, other may feel that more is to be gained by a creative 'blurring' of the meaning. This happens to other words too, and within communication studies we see the original meanings of many words being blurred creatively. The word *language* is a good example, and expanding the definition of a language often goes hand in hand with expansions of the idea of literacy.<sup>2</sup>

## Claiming the status of gateway skills

In modern education and in society generally, skills in literacy are deemed essential. If children leave school unable to draw or dance, it isn't deemed important. If they have difficulty doing sums, it is regretted more, but not thought of as a disaster. But an inability to read and write is an educational catastrophe. Reading in particular is a **gateway skill** because it opens up access to a whole wide world of learning and understanding. Thus literacy – especially its reading component – has long had a high status in educational circles.

One can therefore understand it when visual communicators, educators in media studies, librarians and others start to appropriate the word *literacy* for what they practice and teach. They too believe that they offer **gateways** to understanding and

learning, albeit neglected ones. They hope their contributions to enabling learning can be afforded more attention and thought more important. It is not tempting for them to appropriate the respected word *literacy* and apply it to what they do?

### **What does it mean to be (literally) literate?**

The original meaning of literacy is tied up with **letters** – a system of conventional symbols which represent words. Most writing systems are alphabetic in that these symbols do not represent the words directly, but the sounds which those words use in speech. Learning to read and write isn't easy, and many languages make learning to read even more challenging because their orthographic systems are shot through with inconsistencies, as in English [*bay–weigh–maid; through–though–cough*]. No wonder it takes years to learn to read proficiently, and that learning to write and spell correctly is even more difficult.<sup>3</sup>

Note that literacy is not quite the same as skill in using language! Whether Homer was one person or several working in the great Greek epic tradition, we can be sure that he was (they were?) illiterate. Yet sometimes the phrase 'highly literate' is used of someone to praise their skill in using language. True, the ability to represent your use of language visually (as words on a screen or piece of paper in front of you) is a great tool for thinking about and honing your language use, and we can learn to improve our use of language by reading the writings of others, so this extension from the strict meaning of 'literacy' is at least understandable.

An interesting situation arises if we are faced with language in an unknown writing system, and therefore find ourselves 'illiterate' in that system until it is deciphered. This is what Thomas Young (1773–1829) and Jean-François Champollion (1791–1832) experienced as they tried to decipher Egyptian hieroglyphics. Previous attempts had been misled by a conviction that hieroglyphics represented concepts. Young believed it was a phonetic system, and he used Egyptian transliterations of Greek names in the Rosetta Stone text to identify the relationship between some of these symbols and the sounds they represented. But the real breakthrough came in 1822, when Champollion realised that ancient Egyptian was related to Coptic. Soon afterwards, the world of scholarship had become functionally *literate* in ancient Egyptian, and a whole era of history was opened to investigation.

## **Visual Literacy**

I have been trying recently to trace the use of the term **visual literacy**. Dennis Pett, who for 18 years edited the newsletter of the International Visual Literacy Association, says that he first heard it used in 1950 by photographer Henry Holmes Smith, and links this idea to the appearance around that time of *Photography is a Language* by John Whiting and *Language of Vision* by Gyorgy Kepes. This was also at a time when there was growing interest in the use of photographic filmstrips in education, and photography itself as a medium of communication.

In 1967, the Eastman Kodak company began to publish a series of newsletters called *Visuals are a Language*, edited by John Debes. In August 1968 this led to a gathering to plan a national conference, the *Conference on Visual Literacy*, which took place in March 1969 at the University of Rochester (in Kodak's home town). This led to other conferences and the publication of series of papers, and the organisation became the International Visual Literacy Association in January 1975.<sup>4</sup>

Another strand in the development of the idea of Visual Literacy can be traced to Gestalt psychology. The visual communication aspects of Gestalt thinking found expression in 1969 in a book by Rudolf Arnheim called *Visual Thinking*. Roy Behrens comments on Arnheim's work:

Arnheim intended to narrow the gap between scientific and artistic knowledge, to use scientific findings to better understand the arts while preserving the equally pivotal role of subjectivity, intuition, and self-expression... [He] challenged the age-old distinctions between thinking and perceiving, and between intellect and intuition.

Contending that 'all perceiving is also thinking, all reasoning is also intuition, all observation is also invention', he attacked the established assumptions that words, not images, are the primary ingredients of thinking, and that language precedes perception. Rather, Arnheim argued, 'the remarkable mechanisms by which the senses understand the environment are all but identical with the operations described by the psychology of thinking'. Like scientific discovery, he wrote, artistic expression 'is a form of reasoning, in which perceiving and thinking are indivisibly intertwined.'<sup>5</sup>

Isabel Pedersen of the University of Waterloo in Canada<sup>6</sup> identifies Donis Dondis as another writer on visual communication influenced by Gestalt thinkers, and by Arnheim in particular. Dondis' 1975 book on visual communication, in which she explores a grammar of visual elements (dot, line, shape, direction, tone, colour, texture, scale, motion) is, significantly, called *A Primer of Visual Literacy*.<sup>7</sup> It seems therefore to have been a term that had achieved common currency in those years, at least in the Americas.

When it comes to a definition of visual literacy, the IVLA website still draws on a rather clumsily-expressed one created by John Debes with Roger B. Fransecky for a 32-page pamphlet published in Washington in 1972 called *Visual Literacy: a way to learn, a way to teach*:

[Visual Literacy is] a group of vision competencies a human being can develop by seeing and at the same time having and integrating other sensory experiences. The development of these competencies is fundamental to normal human learning. When developed, they enable a visually literate person to discriminate and interpret the visual actions, objects, and/or symbols, natural or man-made, that are [encountered] in [the] environment. Through the creative use of these competencies, [we are] able to communicate with others. Through the appreciative use of these competencies, [we are] able to comprehend and enjoy the masterworks of visual communications.<sup>8</sup>

Now, this is staking a *very* large claim for the subject-matter of visual literacy – including every natural or man-made object in the environment. Are we really using a form of 'literacy' when we look at a lake, a stone, a tree? Or has the meaning of literacy become so diluted here as to be useless?

### **Exploring the 'Literacy' component in 'Visual Literacy'**

Associating the idea of literacy with a medium surely suggests, if nothing else, that knowledge does not flow from the medium naturally and without effort, but that there is some sort of code or language which one must learn to decode first. Can this said to be true of visual media? Can it also be true of natural phenomena?

As a starting-point, it must be remembered that the written word is itself a visual medium; that 'real' literacy always involves decoding a visual array of symbols into

words. We can go beyond these basic acts of literacy to consider the added meaning of typographical arrangement. Using larger and darker type to denote headings – indenting paragraphs of quoted text – placing text in juxtaposition with pictures to serve as captions... all these arrangement of type have meanings, and we learn to ‘read’ them. Designers exploit these conventions to strengthen the meaning of textual messages as they lay them out on the page, and to give them character.

At this workshop, we are particularly interested in charts, graphs, maps, diagrams. Some of these forms of visual communication use formally-defined symbols and visual conventions. It is easy to think of many kinds of ‘visual explanations’ which require previous knowledge of a language of symbols and conventions in order that we might understand them. Let’s review some obvious examples:

- **Circuit diagrams** use special symbols to identify switches, transistors, resistors, diodes and other components. Part of the training of an electronics engineer is to learn how to decipher them (Fig. 1).

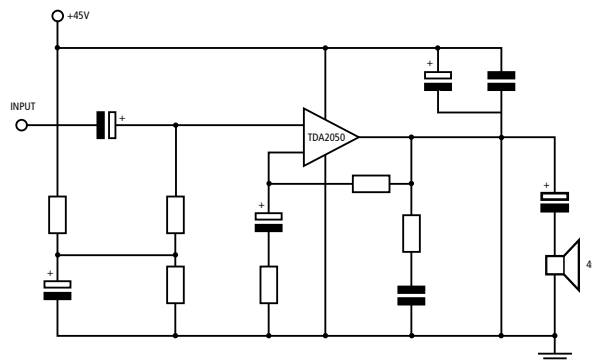

Figure 1. Part of an audio amplification circuit.

- Meteorologists use various kinds of map to present the state of the weather and to present its future development. **Barometric charts** like the one shown below (fig. 2) have great predictive value, but to understand them you have to learn not only what the various lines and symbols mean (isobars, and lines showing weather fronts), but also what they can tell you about wind direction and speed. For weather reports on TV, therefore, barometric data is usually omitted, and TV charts use more naturalistic icons to show clouds, sunshine and rain, arrows for wind direction, and animation.

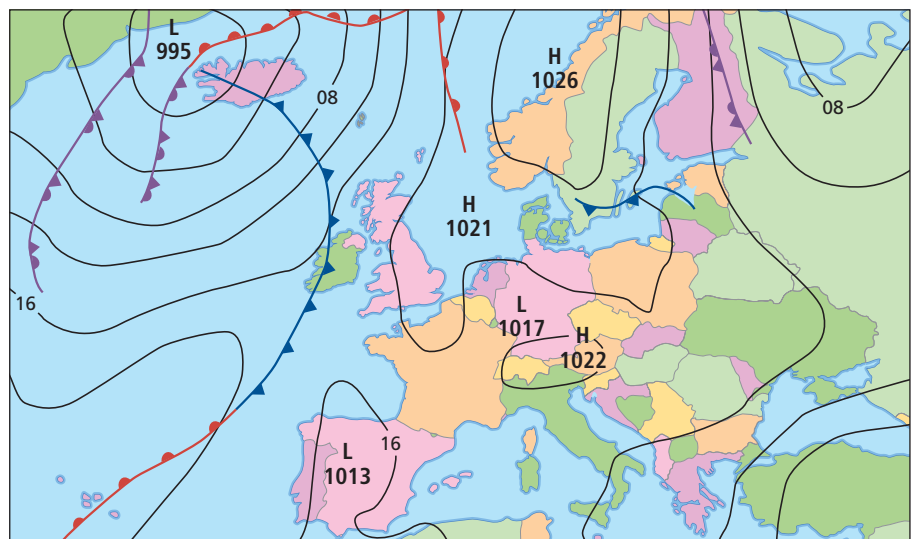

Figure 2. Barometric chart of Europe for 8th August 2003.

- **Bar charts** which represent variation of quantities over time require at least an understanding of scales. And even an experienced person can be taken in at a subconscious level when the baseline does not start from zero, as in this diagram of the number of people using a university library (fig. 3). (The range of variation is only about 8%, but it looks more dramatic.)

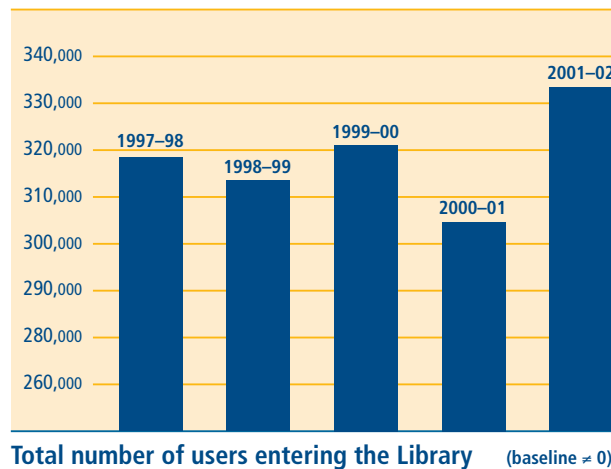

Figure 3. Bar chart designed for the Annual Report of a university library.

- **Road maps** use different colours to distinguish between motorways, major and minor roads. Drivers learn these conventions, together with how to understand junction numbers and the various symbols that show amenities.
- **Node-Link diagram** is a term used by Colin Ware to describe diagrams in which boxes or other container-shapes represent entities, and lines represent the relationships between them. ‘Literally dozens of different diagrams have this basic form, including software structure diagrams, data flow diagrams, organization charts, and software modelling diagrams,’ writes Ware.<sup>9</sup>

It is common in constructing such diagrams to want to distinguish between entities with different sets of attributes and different kinds of links. So we find that boxes vary in width or colour of line, internal colour, size or shape; lines also may vary in thickness, colour, and texture (solid or dotted). There is often also a meaning to the relative position of entities in the diagram (‘left’ can represent the beginning of a process, ‘top’ may represent the higher echelons of an organisation). Thus a diagrammatic language is constructed which must be learned by members of that diagram type’s user community.

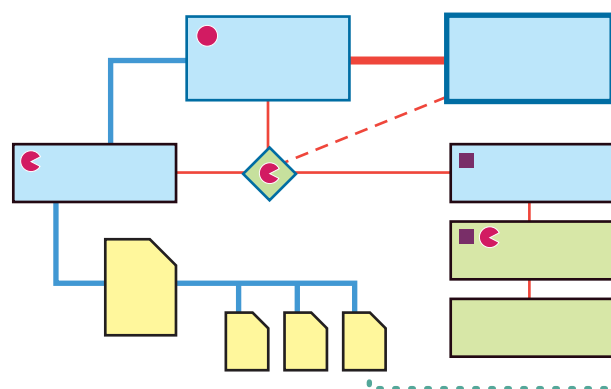

Figure 4. Totally fictitious node-link diagram created to show how variations in shape, colour, outlining and position of ‘entity’ boxes, and variation in ‘link’ lines. Note further use of icons to distinguish entity types.

We can think of a lot more examples of visual conventions that have to be learned to make sense of diagrams, and I’m sure at the workshop we will do so. To me it does not seem so far-fetched to describe this learning process as a kind of ‘literacy’.

## Reading the language of pictograms

Pictograms have a rather special and yet paradoxical claim in relation to the concept of visual literacy. They are often intended to replace language, to meet information needs for a multilingual community – as in the wayfinding signs deployed around airports, railway stations and other public places. Is there a special kind of ‘literacy’ involved in learning what these symbols mean?

There are circumstances in which a ‘language’ of pictograms would be useless if it had to be learned before it could be understood. Don’t the people who design pictograms for airports intend their symbols to be understandable instantly by someone who has flown into the country for the first time? Isn’t their simplified representational form supposed to elicit *instant* recognition of what they denote? A need for ‘pictogram literacy’ is what such designers are presumably trying to *avoid*...

In a discussion of the redesign by Mollerup Designlab of the signs at Copenhagen airport, Per Mollerup explains:

[Pictograms] should be icons. They should be pictures that depict clearly what they mean. A picture of a train stands for railway, a picture of a fish stands for fishmonger, etc. ...

In Copenhagen Airports, [some] pictograms were consistent with their intended meaning but unable to convey that meaning without the help of text. Among the bizarre examples of the old signage systems at Copenhagen Airports, two similar pictograms can be mentioned. One pictogram showed a sitting person handing a ticket over a person to a standing person. [See fig. 5] The other pictogram showed a standing person handing over a ticket to a standing person. The first pictogram meant ‘transfer check-in’. The second pictogram meant ‘ticket office’.<sup>10</sup>

Figure 5



Pictograms seem to be less successful in representing actions and relationships than objects and places. Astute readers may also note that Mollerup’s examples of the train and the fish are what we might call ‘visual metonymy’<sup>11</sup> rather than literal representation – the picture of the train doesn’t represent only the train, and the fish doesn’t represent a fish.

In constructing a national set of road signs and markings, instant recognition on the road is more important than instant comprehension by a person seeing them for the first time. Most drivers in any country have grown up around their nation’s signs, and part of their driving lessons will involve (to use a British example) learning to recognise a No Overtaking sign, and the meaning of double yellow lines. Thus it is reasonable to expect the meanings of these symbols and road markings to be learned – ‘the language of the road’.

(This reminds me of the amusement which my brothers and I obtained on journeys by deliberately inventing wrong meanings for signs [Fig. 6] – and my puzzlement at meeting some American road signs for the first time [Fig. 7].)

Fig. 6 – The Netherlands  
“Bottles may be secured  
with tape to the train  
windows.”



Fig. 7  
Often accompanied  
with the road marking  
PED XING.

## Visual literacy and representational art

As we move away from the abstracted world of maps, node-link diagrams, pictograms and so on towards more representational forms of visual communication, it becomes more difficult convincingly to argue that some sort of quasi-literacy is required before people can elicit meaning from images. Anthropologists who have shown photographs to newly-discovered peoples have found that these people have no difficulty in recognising that these flat depictions represent real people and objects. They may not always understand what is going on in the pictures, but that is a different issue.

However, a survey of the history of art makes it clear that some aspects of pictorial representation are conventional. In many Egyptian paintings, the Pharaoh and other important people are drawn larger; the servants, soldiers and peasants are drawn smaller. In Chinese, Indian and Persian paintings, people who are further away in the scenery are drawn further up in the picture, but not necessarily smaller: the norms of perspective, which dictated that people and objects in the distance be drawn smaller, came in only during the Renaissance period in Europe.

The strip cartoon is a visual communication form with many conventional and artificial aspects. Cartoons and other pictorial sequences are of interest to us in this workshop on Explanatory and Instructional Graphics because they are often used to educate and explain. Here are a few of the conventions which have, perhaps, to be 'learned' by the reader of cartoon books:

- **A sequence of images.** The images tell a story and have to be read in sequence. Other art-forms have done this in the past,<sup>12</sup> but the strip cartoon and the pictorial sequence *depend* on correct reading order to succeed. In Western cultures this normal sequence is the same as reading order – rows of pictures across the page from left to right, and the rows arranged from top to bottom, though sometimes adventurous variations are made such as placing some images inset into others.
- **Cropping of images.** Drawing on precedents from Impressionist painting, photography and the movies, people depicted in cartoons are often 'cut off' by the frame. (I have heard it alleged that a cartoon book intended to promote agricultural techniques in Indonesia was scorned by villagers because, as they pointed out, there are no two-legged oxen in Indonesia – see Fig. 8.)

Figure 8.  
Is it really believable that the Indonesian villagers didn't realise this wasn't 'wholly cow' – or is this story one of those anthropological myths?  
(This drawing by the author)

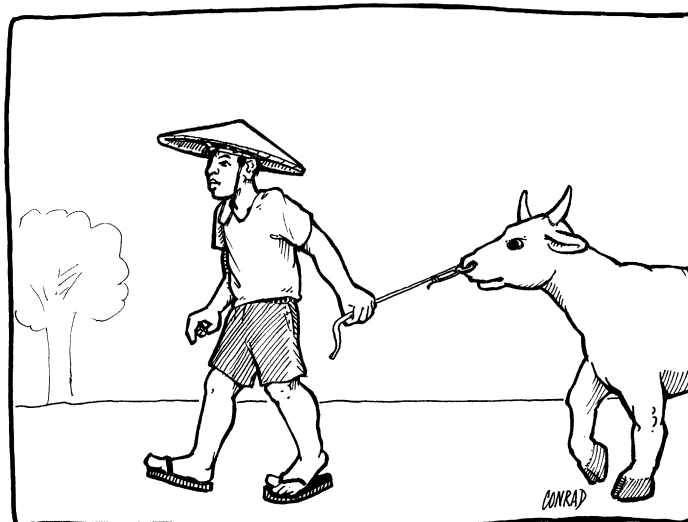

- **Rapid shifts of point-of-view.** In the movies, our point of view as determined by the position and angle of the camera is constantly changing – from wide shot to close-up, from level view to crane shot. Some cartoon strips make little use of this cinematic device, especially the ‘funnies’ in daily newspapers, but others make a great deal of use of it – examples include the Marvel Comics adventures, and French cartoon stories such as Cosey’s *Le Voyage en Italie* and Bourgeon’s *Les Passagers du Vent*.<sup>14</sup> Explanatory graphic sequences use this technique less, but may still alternate between wide shot and close-up to show details of the operations or procedures being described.
- **Changes of scale.** In fact this is usually just an example of changing point-of-view, but scale changes may lead to misunderstandings. The tale is told of a health promotion worker whose attempts to teach food hygiene, using a poster with an enlarged picture of a fly, were undermined because – as her audience remarked – there were no flies of that size in the country.
- **Speech and thought balloons.** The origins of this device is older than many people expect, but has now become formalised such that a round balloon represents speech, a ‘cloud-shaped’ balloon represents thought and a spiky-framed balloon represents speech coming from a device such as a telephone, radio or Tannoy system.
- **Lines of motion and other ‘briffits’.** Cartoonist Mort Walker invented the word ‘briffits’ to describe the lines, clouds of dust, small bells and birds and other devices drawn to indicate swift motion, impact, concussion, drunken stupor, heat and other attributes hard to represent by other means.

For this kind of representational imagery, which is often used in graphics to explain or teach, we *can* say that there are conventions to be learned before they can be understood as communications. To that degree, it doesn’t seem inappropriate to speak of a form of ‘literacy’ being involved. Please also notice that just as normal literacy teaches you to *write* as well as to read, this ‘visual literacy’ informs creation as well as understanding. Knowledge of the conventions in cartooning, or those used to construct particular kinds of diagram such as a Venn diagram or flow chart, provides essential ‘vocabulary’ to the cartoonist and the diagrammer.

### **Visual literacy and the photograph?**

Although it turns out that the history of the ‘visual literacy movement’ is strongly associated with the beginnings of educational uses of photography, for example the promotion in the fifties and sixties of educational filmstrips and slide shows, I am very far from convinced that the word ‘literacy’ applies well to photography and its uses. (If it has an application, it is rather in the loose usage of ‘literacy’ used by the ‘media literacy’ movement described in the next section.)

Quite simply I do not see photography as having that many ‘conventional’ elements in its toolkit – that is to say, more or less arbitrary associations of meaning with visual elements – certainly nothing like the way in which symbols and colours and line weights carry meaning in the diagram examples shown above (e.g. Figures 2 and 4). Surely it is that *need to learn a symbolic language* which makes learning how to interpret maps and diagrams rather like learning how to read? – and photography does not share that characteristic.

## Media literacy

I must here confess two things. Firstly, until about six months ago I had never heard the term 'media literacy'; secondly I have been amazed to discover through searches of the Web just how widespread its use is in the sphere of education, especially in the United States and Canada where the term seems to have been in use for at least 25 years. A current initiative of the British Government means that it's becoming a buzzword in British education circles too.

Various organisations on both sides of the Atlantic have the objective of promoting 'media literacy', including the Alliance for a Media Literate America (AMLA), the Association for Media Literacy (AML, in Canada), and also the Center for Media Literacy (CML) which acts as a resource provider for schools in the USA – where Media Literacy has become part of the curriculum at primary and secondary levels. In Britain there is now the Media Smart® website, recently set up by the Department of Culture, Media and Sport (DCMS) and aimed at children's education.<sup>16</sup>

### Where has 'media literacy' come from?

By reading the 2001 *Media Literacy Statement* by the Broadcasting Policy Division of the DCMS,<sup>17</sup> and from other statements on the websites of the organisations I've mentioned, one gets a picture of where this concern has come from. Educators and policymakers have become concerned about the impact which the mass media has on the attitudes and world-view of children. Children's attitudes to violence, to sex, to substance abuse and to gender and race stereotyping are frequently mentioned, as is the propensity of children to be easily manipulated by advertising. It is felt that children must be armed with skills of critical reflection in relation to the media.

How is 'media literacy' defined? The Alliance for a Media Literate America writes:

Media literacy empowers people to be both critical thinkers and creative producers of an increasingly wide range of messages using image, language, and sound. It is the skillful application of literacy skills to media and technology messages. As communication technologies transform society, they impact our understanding of ourselves, our communities, and our diverse cultures, making media literacy an essential life skill for the 21st century.<sup>18</sup>

The UK DCMS *Media Literacy Statement 2001* (as quoted by the Media Smart® site) unpacks some of the requisite skills thus:

Perhaps the most important characteristic of critical viewing is the ability to think critically about viewing – *i.e.* to understand why one likes or dislikes certain programmes or genres and relate such preferences to moral and intellectual reference points; and, having done so, to take greater responsibility for viewing choices and the use of electronic media, for both oneself and one's children. Specific 'skills', in this sense, might include:

- The ability to distinguish fact from fiction...
- The ability to identify and appreciate different levels of realism...
- A better understanding of the actual mechanisms of production and distribution of TV programmes, CD-ROM games, films, interactive software, websites etc...
- The ability to differentiate reportage from advocacy...
- Awareness and assessment of commercial messages within programmes (product placement etc) and a critical approach to advertising...

- An awareness of the economic and presentational imperatives that underlie news...
- The ability consciously to explain and justify media preferences...<sup>19</sup>

A number of statements in favour of media literacy education point to the increasingly screen-based nature of culture, and the tendency for the modern child to have access, often in his or her own bedroom and without adult supervision, to television and videogames and the Internet. As the CML explains:

With media technology becoming so prevalent in homes, and with multi-media education more possible now with student access to computers and the Internet, 'media literacy' expands the basic concept of literacy (*i.e.* 'reading' and 'writing') to all forms of communication – from television to T-shirts, from billboards to multi-media environments.<sup>20</sup>

### Media Literacy education in schools

The Center for Media Literacy points to the growing involvement of schools in the USA with media literacy education:

Although media literacy is still a new idea for many teachers and schools, we see signs of media literacy growing everywhere, for example:

- The National Middle Schools Association named media literacy one of three 'hot topics' for its 2002 national conference attended by over 8500 teachers. Media literacy workshops at the conference were standing-room-only.
- Reports from major foundations and educational agencies are calling for media literacy as a critical component of education for the 21st century.
- The McREL national educational standards database has added two new strands: *viewing* and *media* to English/language arts for kindergarten through high school. Standards are also beginning to appear in social studies, health, art and lifeskills education in all 50 states.<sup>21</sup>

In the United Kingdom, Media Education is now compulsory from Key Stage 3 of the National Curriculum, primarily as a part of English. The official National Curriculum, under the 'Media and Moving Image Texts' section of *Citizenship through English*, directs that:

Pupils should be taught:

- a) how meaning is conveyed in texts that include print, images and sometimes sounds
- b) how choice of form, layout and presentation contribute to effect [for example, font, caption, illustration in printed text, sequencing, framing, soundtrack in moving image text]
- c) how the nature and purpose of media products influence content and meaning [for example, selection of stories for a front page or news broadcast]

Under the heading *non-fiction and non-literary texts*, it states:

The range should include:

- a) literary non-fiction
- b) print and ICT-based information and reference texts
- c) media and moving image texts [for example, newspapers, magazines, advertisements, television, films, videos]

Finally, I return to the AMLA web site for its extended definition of media literacy, its importance, and who are the people pushing for media literacy education:

Within North America, media literacy is seen to consist of a series of communication competencies, including the ability to **access, analyze, evaluate** and **communicate** information in a variety of forms including print and non-print messages. Interdisciplinary by nature, media literacy represents a necessary, inevitable and realistic response to the complex, ever-changing electronic environment and communication cornucopia that surrounds us.

To become a successful student, responsible citizen, productive worker, or competent and conscientious consumer, individuals need to develop expertise with the increasingly sophisticated information and entertainment media that address us on a multi-sensory level, affecting the way we think, feel and behave.

Today's information and entertainment technologies communicate to us through a powerful combination of words, images and sounds. As such we need to develop a wider set of literacy skills helping us to both comprehend the messages we receive, and to effectively utilize these tools to design and distribute our own messages. Being literate in a media age requires critical thinking skills which empower us as we make decisions, whether in the classroom, the living room, the workplace, the board room or the voting booth.

Finally, while media literacy does raise critical questions about the impact of media and technology, it is not an anti-media movement. Rather, it represents a coalition of concerned individuals and organizations, including educators, faith-based groups, health care-providers, and citizen and consumer groups, who seek a more enlightened way of understanding our media environment.<sup>23</sup>

(Please note that because of my lack of direct involvement with or knowledge of media literacy campaigns and projects, I have had to rely in this section extensively on quotes from available sources.)

### **OK, it's important, but it is Literacy?**

I find myself strongly in favour of helping children (and adults) gain critical skills in thinking about and evaluating our modern media. I find myself less well disposed towards accepting these skills as a form of 'literacy' unless it be with those inverted commas that indicate metaphorical use.

- 'Media Literacy' as described does not centrally involve learning any formal, conventional systems of letters, symbols or codes by means of which ideas are communicated. If this is a test of what a 'literacy' is, I would say that some of our examples in the 'Visual Literacy' category would pass that test (e.g. diagrams, maps and pictograms) – but 'Media Literacy' education would largely fail it.
- If there is a precursor to 'media literacy education', it is the critical study of literature, and also to an extent art criticism. I find it an interesting 'slip' that the UK National Curriculum describes movies and videos as 'moving image texts' and places the responsibility for their study within the English curriculum. To me this also indicates a possible connection and continuity, at least in the UK, with postmodern literary criticism and its extended range of targets across the arts. And it prompts me to declare that media education is about **literary skills** rather than **literacy skills**.

- However, this kind of media education, especially for young people as described above, does share with true literacy the attribute of being what we can describe as a **gateway skill** – one which empowers people to take control of how all kinds of media inform, educate and influence them.

I am therefore disposed to allow Media Literacy as a *metaphorical* use of the term – while noting, with a sprinkling of cynicism, that there is something of a campaign to get Media Literacy accepted into the primary and secondary school curriculum, and the magic status of Literacy is probably being manipulated by its proponents to ‘boost’ the importance of subject.

## Information Literacy

I should also say that I had not, until nine months ago, heard anyone use the phrase ‘Information Literacy’. Since then I have learned that it is a term invented by another community mostly within the education system – namely teachers of Information Management, and university and college librarians.

The term seems to have originated towards the end of the 1980’s, in the librarianship community in the USA, and in 1989 the Final Report of the American Library Association (ALA) Presidential Committee on Information Literacy defined it thus:

To be information literate, a person must be able to recognise when information is needed and have the ability to locate, evaluate and use effectively the needed information. Ultimately information literate people are those who have learned how to learn.

That is substantially the same definition as the one promoted by the (US) National Forum on Information Literacy (NFIL), a coalition of 65 organisations which was set up to disseminate the concept of Information Literacy as a result of the ALA’s 1989 report.<sup>25</sup> This definition is also quoted with comfort by the (US) Association of College and Research Libraries, and by organisations of Australian and British university librarians.

### What is the problem?

NFIL also describes on its home page the ‘problem’ to which information literacy education is seen as the solution. Referring to the deliberations of the Presidential Committee of the ALA that reported in 1989, they say:

These education, library, and business leaders stated that no other change in American society has offered greater challenges than the emergence of the Information Age. Information is expanding at an unprecedented rate, and enormously rapid strides are being made in technology for storing, organizing, and accessing the ever-growing tidal wave of information. The combined effect of these factors is an increasingly fragmented information base, a large component of which are available only to people with money and/or acceptable institutional affiliations. In the recent past, the outcome of these challenges has been characterized as the ‘digital divide’.

The problem, to paraphrase a number of sources, is that students (especially in higher education) are required and expected to find information for themselves to fulfil their study and research requirements. Furthermore, in the context of aspirations to prepare people for **lifelong learning**, an ability to find relevant information efficiently and make use of it well is not only a valuable skill as a means

to immediate ends, but also one of the most valuable of **gateway skills**. However, most students do not arrive in higher education knowing how to use a library efficiently, and they must be taught this skill. The problem has been compounded in the last fifteen years by at least three factors – the computerisation of library catalogues, the increasing role of electronic journals and even textbooks, and the growth of the World Wide Web as a relevant information source. Hence the ‘tidal wave’ referred to in the NFIL statement.

To some extent, training in ‘Information Literacy’ can be seen as an updated version of the library skills courses available for some time in higher education. A major aim of these has been to help students formulate and pursue search strategies. Because of technical developments, searching for information now also requires an understanding of search engine interfaces and Boolean logic; there has been a temptation to identify these as Information Technology (IT) skills. But with its emphasis on *non-IT* skills in searching for and handling information, the idea of ‘Information Literacy’ has been a useful and necessary corrective to that techno-focused mistake.

### **The critical difference**

Proponents of ‘Information Literacy’ have added an important non-IT skill to the repertoire of skills required for information search, retrieval and use in educational contexts – the ability to make **critical assessments** of the usefulness or trustworthiness of information sources, and the relevance of information retrieved from them.

In part this is surely a response to a phenomenon known to all too many teachers in secondary and higher education today: the regrettable ease with which lazy students Google for material on their assignments, copy the contents of a few Web pages of dubious validity and paste those contents straight into a word-processing document – and *voilà*: an ‘essay’. Not only is this plagiarism, it is assuredly not education, a failure to use the only information network that really counts in education – the one which consists of neurons!

Thus we can see that ‘Information Literacy’ has developed some important parallels with ‘Media Literacy’. In both of these concepts, a critical approach to sources has become central to the definition.

### **The SCONUL model of Information Skills**

In the British context, a significant document describing this important collection of skills is the position paper drawn up by a working party which came together in December 1998 for this purpose, established by SCONUL – the Society of College, National and University Librarians.<sup>26</sup>

The SCONUL paper is partly a critique of the Dearing Report of 1998 from the National Committee of Enquiry into Higher Education, which claimed to identify skills ‘key to the future success of graduates whatever they intend to do in later life’. Dearing identified four such key skills: communication skills, numeracy, use of information technology, and learning how to learn. A paper by Shiela Corral, Librarian at the University of Reading, criticised the Dearing Report for failing adequately to consider ‘information handling skills’ – which she defined as covering knowledge of information sources, criteria for evaluating them, skills in navigating their interfaces, techniques for manipulating information, and presentation issues. This is in odd contrast to primary and secondary education, where information

skills had already been recognised as important by BECTA, the UK government's Education Communications and Technology Agency.<sup>27</sup>

The SCONUL group noted that some people use the term 'information literacy' to encompass these various abilities to work well with modern information sources, and defined seven '**headline skills**' as essential to this:

- The ability to recognise a need for information.
- The ability to distinguish ways in which the information 'gap' may be addressed [ *this involves knowledge of information sources and the ability to make judgements about their availability* ].
- The ability to construct strategies for locating information [ *this involves knowledge of search methods and how databases are constructed and may be accessed* ].
- The ability to locate and access information [ *including skills in constructing Boolean search strings, using communication and information technologies, and indexing and abstracting services* ].
- The ability to compare and evaluate information obtained from different sources [ *including awareness of issues of bias, authority, peer review etc.* ].
- The ability to organise, apply and communicate information to others [ *including skills in communication, and in citation and bibliographic construction, plus awareness of issues of copyright and plagiarism* ].
- The ability to synthesise and build upon existing information, contributing to the creation of new knowledge.

The SCONUL report does a good job of identifying these component skills, but is then marred by a confused discussion of how these skills are acquired stepwise and iteratively. (Here, however, is not the place to get into a discussion of *that* problem.) Suffice it to say that, as framed by SCONUL and other librarians' organisations who have been the main pushers of this idea of 'Information Literacy', the dominating and defining concern is with how students and researchers in higher education acquire information and use it in their academic projects.

### **Again – it's important stuff, but is it Literacy?**

I am even less convinced in this instance by the appropriation of the term 'literacy'. To their credit, the SCONUL working party also seemed to show unease with the term by using it mostly within inverted commas. Again, I suspect that the motivation for misappropriating the L-word has been to help in the campaign to establish these skills as important gateway skills in education – which without doubt they are.

Two other points are worth making here:

- Some large claims have been made that 'Information Literacy' is the solution to all sorts of problems in human development, and in particular all kinds of **lifelong learning** situations. But if this case is to be argued convincingly, other more general models of information skills will need to be developed that have more natural applicability outside the university context than those on offer from the university library community.

- I would have thought that implicit in the idea of ‘literacy’ is that such learning empowers one to **create** information sources, not merely consume them. The librarianship model of information skills describes merely information acquisition, and this appears to me to be one of its shortcomings.

(These critiques of the SCONUL model were made in the course of a workshop<sup>28</sup> held in London on 21 January 2003 by the Information for Development Forum, and readers might like to download the report from that workshop.<sup>29</sup>)

## A diversity of ‘literacies’

Apart from the three so-called literacies discussed so far in this paper, others have been talked about loosely – including ‘**digital literacy**’, which is apparently a fancy way of saying ‘knowing how to use a computer’.

In a message circulated to the group preparing the 21 January 2003 workshop on Information Literacy, Alan Hancock made interesting observations on how many of these ‘new literacies’ came to be invented, though he concentrates largely on the history of the ideas of **media literacy** and **information literacy**:

The term ‘literacy’ is one of the underlying problems. Formal definitions of literacy emphasise two skills: the ability to read and write; and the ability to use language proficiently. The concept was important in education, in part because it provided a foundation in post-war years for international action and measurement; once quantified (*i.e.* defined as the ability to read a specific, simple text, or express a simple thought in writing) it could be used as a basis for international campaigns, and for target-setting (*e.g.* achieving an agreed level of literacy by a set date, such as the year 2000).

To many, however, the concept of literacy posed more fundamental problems. Michael Young, writing in 1971, highlighted the emphasis it placed on written as opposed to oral presentation; Richard Hoggart, Stuart Hall and many more saw this division (and the moral judgements to which it often led, distinguishing between ‘high’ and ‘low’ culture) as elitist, discriminatory and finally unhelpful in understanding the new society.

Others found that the concept was both too rigid, and too general, to illuminate the particular slant on literacy with which they were concerned. So they added – first **numeracy** (which became part of the classic box of skills supposedly required for social functionality), then **functional literacy** (the skills needed to survive and prosper in the workplace). These were easily incorporated into the international, educational tradition, as they tended to be skills-oriented.

Thereafter, however, the situation became more complex. While running the risk of over-simplification, we might position later perspectives – and the terminology to which they gave rise – along an axis running from *skills* to *critical understanding*. At one side, there is the notion of proficiency, the ability to master certain skills and make effective use of certain instruments (a technical and methodological perspective). At the other end is a more socio-cultural perspective of understanding: a critical and investigative approach to meaning, to codes and protocols, towards attitudes to mass media, to the effects and impact of innovation and technology.

We can place not only **computer literacy** and **information literacy**, but also **media literacy** and **media education** (and even, rarely, **emotional literacy**) along this axis (with the former closer to *skills*, and the latter closer to *critical understanding*). Each of these approaches has had its primary constituency (librarians,

information technologists and the professional associations which represent them have embraced the information literacy tradition, and social scientists, media researchers and their professional groupings have favoured media education). Teachers have often divided according to their own disciplinary background.

It seems to me that, in this evolutionary process, several things have occurred. In the first place, the underlying notion of 'literacy' has lost much of its meaning; in its later manifestations it simply implies 'proficiency' or 'ability to deal with' a stated field. Secondly, and more unfortunately, the attempts to focus on specific fields or phenomena (computer, media etc) have had the effect of dividing and demarcating perspectives, rather than linking and integrating them.

This seems to be mirrored in the definitions employed, especially by professional bodies. In [the American Library Association definition of 1989 – see p. 12 above]... the emphasis is demonstrably on learning skills, formulating questions, data processing and evaluation, analytical reasoning and problem solving.

Contrast this with a relatively early (1989) definition of media education in the Second Cox Report:

Media education seeks to increase children's critical understanding of the media... How they work, how they produce meaning, how they are organised and how audiences make sense of them.

This is more in keeping with social and cultural research traditions, and indeed the core work on media education in the UK was carried out at the BFI [British Film Institute] and at the Centre for Mass Communication Research at Leicester (both were significant contributors to the broader UNESCO-inspired debate).

I would not want to make too much of this divide. Many teachers and researchers have done their best to cross it, realising that both skills and understanding are necessary. But the two traditions do persist, re-inforced by professional needs and backgrounds which reflect a different set of world views. Even in the international organisations, such as UNESCO, the parallel development of the two traditions, placed for much of their life in separate, watertight structures drawing on their own NGO constituencies, has made bridge-building difficult.

A new, more rounded understanding is necessary (I would like to suggest a new terminology, but at this late stage in the debate, any attempt to change the terms would probably be counter-productive, and an enlargement of sensibility is a more realistic hope).<sup>30</sup>

## Literacies & language systems

All three of the 'new literacies' discussed in this paper are terms that were invented in the United States of America, where this kind of metaphorical hijacking of words may be more commonplace (another example: *information architecture*<sup>31</sup>). As for why and how information-handling competences and media studies got to be dubbed 'literacies' in the context of the British educational system, Alan Hancock's explanation is persuasive.

Like Alan, I wish we could re-invent our terminology, because I think the concept of literacy is at its most powerful when it means a proficiency in reading and writing systems for encoding ideas in visual form. I don't think 'literacy' should mean just any old kind of proficiency (what's next – 'culinary literacy'? 'driving literacy'? – though in the face of continued adaptation and use of the terms 'media literacy' and 'information literacy', objecting to them may be a bit like regretting that the phrase 'a gay parade' has changed in meaning over the years.

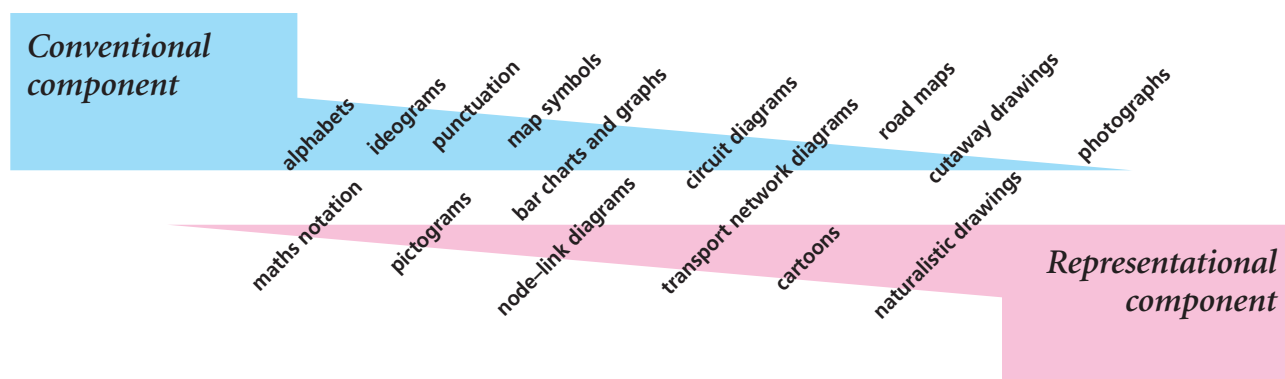

Figure 9 – a spectrum of visible language. At the left side, the signifiers are highly conventional and do not greatly use factors such as position to convey their meaning. The mappings between visible marks and their meanings has to be learned and we can call this learning **literacy**. We similarly have to learn how spatial arrangement is a carrier of meaning in charts, graphs and node-link diagrams.

As we move towards the right of the spectrum, meaning is carried more by pictorial representation, and less by the use of conventional symbols. Maps are an odd hybrid, because underlying topography is represented pictorially and the superimposed symbols are conventional. (However, topographically transformed maps like the London Underground diagram are less representational.) By the time we get to naturalistic drawings and photographs, literacy is no longer a requirement.

### Visible language, a spectrum

For me, the primary meaning of the word **Literacy** must continue to be about becoming fluent in the skills of reading and understanding communications, and constructing new communications, using some kind of system of visible, meaningful signs – what we can call **visible language**.

John Locke, in his *Essay on Human Understanding*, was thinking of a range of types of visible language when he wrote:

The Third Branch may be called *semeiotike*, or *the Doctrine of Signs*, the most usual whereof being Words ... the business whereof, is to consider the Nature of Signs, the Mind makes use of for the understanding of Things, or conveying its Knowledge to others.

Most visible language is encoded in **alphabetic systems** which require knowledge of a spoken language to make interpretation possible. Some visible language is in **ideographic** form, such as Chinese, and it is interesting that there are a number of Chinese ideograms which have crossed a deep language barrier, and work as *kanji* in Japanese to have the same meaning (e.g. the symbol for ‘moon’ and ‘month’). It is also interesting to see how European **punctuation** innovations such as the question mark and exclamation mark have been adopted in East Asian languages.

**Mathematical notation** is a very precise formal system of visible marks which is used internationally, but of course is understood fully only by those who have studied maths to a high degree. Still, most people understand *plus*, *minus*, *equals* and the signs for multiplication and division. (The other formal notation system which has achieved international use within its community is musical notation on the staff.)

I conceive of these methods of communicating as being at one end of a spectrum of visible language types, as I have illustrated above in Figure 9. To the left I place forms of communication which are very language-like and based on conventions, which require to be learned. As we move across the spectrum, communication relies less on conventions – and the language-like features (and a corresponding need for ‘literacy’) is less marked.

Moving along the spectrum of meaningful marks, then, we come to **pictograms** and **symbols**, which do not rely on knowledge of natural spoken language to convey their meaning and are often able to work *across* linguistic communities. They often depict an object, though the relation between the object depicted and the thing represented is usually metonymic to a lesser or greater degree. Thus a picture of a man represents male toilet facilities, a cycle indicates a pathway usable by cyclists, a train represents a station, the fish stands for the fishmonger. The meaning can often be guessed at, but the guess may be wrong and there is still the need to learn these meanings.

Other pictograms and symbols are more abstract, but are understood because their meanings have been disseminated widely, such as the symbols on VCRs and other media players for *play, fast forward, reverse, stop, pause* and *record*. Astronomical/astrological symbols are also internationally widespread, as are religious and political symbols (cross, crescent, swastika, hammer and sickle).<sup>32</sup>

As I have tried to show on page 4 and following, many kinds of **chart, diagram, graph** and **map** require interpreters of them to have made themselves familiar with the meanings conventionally attached to the symbols and use of colour, line weight, position and other features. However, as with pictograms, the relationship between signifier and signified is not *completely* arbitrary. As Colin Ware nicely puts it:

Diagrams are always hybrids of the conventional and the perceptual. Diagrams contain conventional elements, such as abstract labelling codes, that are difficult to learn but formally powerful. They also contain information that is coded according to perceptual rules, such as Gestalt principles. Arbitrary mappings may be useful, as in the case of mathematical notation, but it is important that a good diagram take advantage of basic perceptual mechanisms evolved to perceive structure in the environment.<sup>33</sup>

**Geographical maps** are more representational in nature, although the nature of the representation is a paradoxical one – the shape of Britain, for example, was well known through the maps that had been made of it using surveying methods, long before anyone was hoisted high enough into space to point and say, ‘Ah, that’s Britain!’ Until then, the map was a representation of something that could not be seen except in parts. Maps of necessity have a strong representational component. But superimposed on this representation are conventionally meaningful features such as symbols, shading and colouring and texture, contour lines and other components.

Maps always involve distortion when a spherical object is converted via a projection to a flat representation (e.g. Mercator’s Projection). In the public transport and wayfinding diagrams, the distortions inflicted on geography are often more gross – we call it **topographical transformation** – and are done with the aim of making the routes easier to follow (the London Underground diagram is a well-known example, and much copied). Similarly, Colette Jeffrey’s diagrammatic guide to the British Library rips the floors hundred of metres apart; assembly or maintenance guides for equipment may have the parts exploded outwards on an isometric projection. There is a sort of ‘grammar’ about how these representations are constructed that has also, to some degree, to be learned.

I have no qualms at all about accepting the term Visual Literacy when it applies to all these kinds of visual representation which communicate in a way that require us to learn the conventions of signification and meaning. But I find it much harder

to accept that any kind of ‘literacy’ is involved in understanding photos and realistic drawings. I am not at all denying that there are skills involved in interpreting photographs and paintings – see for example the critical writings of Susan Sontag and John Berger. But those skills I feel, are more similar to skills in literary and sociological criticism, like the skills one learns in media studies; they are not like learning to read and write.

### **Visual Information Literacy**

If I may be permitted, in closing this essay, to attempt to coin my own phrase, may I propose that we accept the existence of the field of **Visual Information Literacy**. By that phrase, I’m proposing a re-interpretation of the idea of ‘visual literacy’, which is perhaps too broad and messy to be useful, to concentrate on studying only the sorts of visual communication which occupy the middle part of my spectrum chart in Figure 9 – diagrams, maps, charts, graphs, explanatory pictorial representations and so on. Those, of course, are also the sort of communication media with which we are concerned at this workshop, so there really is a nice fit between ‘explanatory and instructional graphics’ and ‘visual information literacy’.

To make sense of these visual communications, we rely a great deal on our normal human perception, but we also employ various conventions when we map meaning to symbols and illustration components. Therefore, an adequate study of this field will involve cognitive/perceptual psychology on the one hand, and semiotics on the other,<sup>34</sup> as well as a sensitivity to cultural relativism in the way meanings are attached e.g. to symbols and colours and directions.<sup>35</sup>

In creating explanatory and instructional graphics, we sometimes employ images alone. More usually, words are attached to the graphics – whether as labels for parts or names for places, or perhaps longer embedded explanations. There is something of a sub-family of graphics-with-text, which some writers such as Bob Horn with his concept of ‘Visual Language’<sup>36</sup> and Sven Lidman with his ‘Lexivisuals’<sup>37</sup> would endow with a special status and importance. Personally, I’m not in favour of treating word-and-picture diagrams as a specialised or privileged type.

### **Learning to be better at visual communication**

Is the need for ‘visual information literacy’ a good thing? Designers of explanatory graphics will always aspire to diminish the amount of ‘literacy’ required to understand their diagrams, whether by latching onto what viewers/users already know, or by ‘pictorializing’ in a way that best exploits the natural human perceptual system.

This aspiration is perhaps similar to that of a writer of health information leaflets who is trying to communicate an unfamiliar subject using the clearest and simplest possible language. Such clarity and simplicity is, as we know, not easy to achieve.

We may regret that too many people leave school unable to write clearly, but at least we must admit that ‘literal literacy’ – the ability to work well with words – is a privileged subject in our education system. In contrast, training people to communicate visually is given little or no emphasis in general education.

Perhaps a good case could be made for Visual Information Literacy Education – the only problem would be its acronym! ■

## Notes

- 1. Explanatory & Instructional Graphics and Visual Information Literacy** – a workshop organised by Conrad Taylor of the InfoDesign-Café email discussion list and Susie Andretta of London Metropolitan University. This paper was circulated prior to the meeting to help frame the discussions.  
See [www.ideography.co.uk/infodesign/eigvil/](http://www.ideography.co.uk/infodesign/eigvil/)
- A narrow definition of language is — a system for the expression of thoughts, feelings, facts etc. through the use of words and other spoken sounds, and the writing systems which convey those to a reader. By established convention, this is extended to include the use of signs, symbols, pictograms and other collections of meaningful signifiers.  
Yuri Engelhardt called his 2002 thesis ‘The Language of Graphics’ and in that he makes quite a good case for considering not only the symbols within graphics as language, but also factors such as dimensions and directions as carriers of meaning. When we hear expressions such as ‘the language of music’ or ‘the language of colour’, however, we may feel that the meaning of *language* has become blurred far beyond its commonly-agreed boundaries.
- I don’t know of any comparative studies in the relative ease of acquiring basic literacy for different language communities, but would be fascinated to know more about this subject. Malay/Indonesian, for example, has a restricted number of sounds, does not inflect its word endings and is not a tonal language. Following consultations between the Malaysian and Indonesian authorities, the ‘bahasa’ now has a highly consistent spelling system. Does this result in Malay and Indonesian children learning to read faster than equivalent French or English children? And is the gap between learning to read and learning to spell properly narrower for Malay kids due to the consistency of the spelling system?
- The International Visual Literacy Association website is at [www.ivla.org](http://www.ivla.org). The history here has been abbreviated from [www.ivla.org/organization/history.htm](http://www.ivla.org/organization/history.htm)
- Rudolf Arnheim: The Little Owl on the Shoulder of Athene* by Roy R Behrens; an essay – see <http://mitpress2.mit.edu/e-journals/Leonardo/isast/articles/arnheim.html>
- Isabel Pedersen’s excellent bibliography, created for students of multimedia design, can be found at [www.arts.uwaterloo.ca/~ipederse/navigate.html](http://www.arts.uwaterloo.ca/~ipederse/navigate.html)
- A Primer of Visual Literacy* by Donis A. Dondis; 1973, The MIT Press.
- Visual Literacy: A Way to Learn – A Way to Teach* by Roger B. Fransecky & John L. Debes, published in Washington DC, 1972, by the Association for Educational Communications and Technology.
- See from page 222, ‘The Perceptual Syntax of Diagrams’, in Colin Ware’s *Information Visualization*. [Ware 2000].
- Per Mollerup’s article *The way in to the way out: signage design at Copenhagen Airports* appeared in Volume 10, number 1 of the *Information Design Journal*.
- Metonymy is the name of the figure of speech in which a part means the whole, or an attribute represents its owner: for example ‘Lord Smythe represents *the Crown* in this case’ – ‘*the pen* is mightier than *the sword*’. What we might call visual metonymy is rife in the design of pictograms. Consider some examples from map symbols: an elephant represents a zoo, a knife and fork represents a restaurant.

12. The Bayeux Tapestry is an old example of sequenced pictures telling a story, as are series of paintings depicting the Stations of the Cross. Illustrated books, especially books for young children, tell a story through an image sequence but do not rely exclusively on the pictures for this purpose.
13. In the paper *An exploratory study of reading procedural pictorial sequences*, Carla Spinillo gives examples of such picture sequences (how to assemble devices, how to use sanitary towels), and reports on experiments she conducted with a sequence of four images to test which arrangement was most often read in the correct order. See *Information Design Journal* vol. 10, no. 2.
14. I shall bring these books to the EIGVIL workshop for participants to study.
15. Examples of changes of point-of-view abound in the procedural pictorial sequences used in DIY books – for example the Collins *Complete Woodworker's Manual* and Singer's *Complete Photo Guide to Sewing*.
16. Here are the URLs for these web sites:
  - Association for Media Literacy (AML)— [www.aml.ca](http://www.aml.ca)
  - Alliance for a Media Literate America (AMLA)— [www.amlainfo.org](http://www.amlainfo.org)
  - Center for Media Literacy (CML)— [www.medialit.org](http://www.medialit.org)
  - Media Smart® — [www.mediasmart.org.uk](http://www.mediasmart.org.uk)
17. *Media Literacy Statement* by the Broadcasting Policy Division of the DCMS — see [www.culture.gov.uk/PDF/media\\_lit\\_2001.pdf](http://www.culture.gov.uk/PDF/media_lit_2001.pdf)
18. From the AMLA Web page *About Media Literacy* – [www.amlainfo.org/medialit.html](http://www.amlainfo.org/medialit.html)
19. From the *Key Principles of Media Literacy* page of the Media Smart® Web site: [www.mediasmart.org.uk/media\\_literacy/key\\_principles.html](http://www.mediasmart.org.uk/media_literacy/key_principles.html)
20. From the *Frequently Asked Questions page on Best Practice* of the Center for Media Literacy Web site: [www.medialit.org/faq\\_best.html](http://www.medialit.org/faq_best.html)
21. From the same CML FAQ page.
22. From the *Media Literacy in the UK* page of the Media Smart® Web site: [www.mediasmart.org.uk/media\\_literacy/media\\_lit\\_uk.html](http://www.mediasmart.org.uk/media_literacy/media_lit_uk.html)
23. From the AMLA Web page *About Media Literacy* – [www.amlainfo.org/medialit.html](http://www.amlainfo.org/medialit.html)
24. National Forum on Information Literacy – [www.infolit.org](http://www.infolit.org)
25. This according to a Digest prepared by Eric Plotnick for ERIC, the Educational Resources Information Center – see [www.ericfacility.net/ericdigests/ed427777.html](http://www.ericfacility.net/ericdigests/ed427777.html)
26. The SCONUL position paper is available as a Microsoft Word document on the SCONUL web site: [www.sconul.ac.uk/publications/99104Rev1.doc](http://www.sconul.ac.uk/publications/99104Rev1.doc)
27. BECTA, British Educational Technology and Communications Agency – [www.becta.org.uk](http://www.becta.org.uk)
28. *Information Literacy and the World Summit on the Information Society* was a workshop held on 21 January 2003 by the Information for Development Forum. See the workshop web site – [www.ideography.co.uk/wsis-focus/](http://www.ideography.co.uk/wsis-focus/)
29. Workshop report *Information Literacy, the Information Society and international development* – [www.ideography.co.uk/wsis-focus/meeting/21jan2003report.html](http://www.ideography.co.uk/wsis-focus/meeting/21jan2003report.html)
30. Alan Hancock's message was originally circulated by email and later posted as a position statement on [www.ideography.co.uk/wsis-focus/positions/hancock\\_01.html](http://www.ideography.co.uk/wsis-focus/positions/hancock_01.html)

31. The term ‘information architecture’ is used for many activities which others would call *information design*, and may have been adopted for status reasons (architects are more respected than designers and can charge more money). The term has been promoted by Richard Saul Wurman – an American information designer and writer who trained originally as a architect. It tends to be applied to the design of information-providing *systems* such as Web sites, echoing the system-wide responsibilities which architects bear.
32. *Dictionary of Symbols* by Carl G Ljungman (in Swedish, *Symboler – västerländska ideogram*) is a illustrated compendium and explanation of symbols used through the ages in the Near Eastern and European cultures. It includes signs used to denote religious concepts, alchemical and astrological signs, ‘hobo signs’ used by tramps, signs used in computer flow charting, and many more. (English edition published by ABC-CLIO, Santa Barbara, California USA; 1991.)
33. Colin Ware, *Information Visualization* – published in 2000 by Morgan Kaufmann (Academic Press), San Francisco USA. This quote occurs at the start of the section called ‘The Perceptual Syntax of Diagrams’.
34. This willingness to yoke the two horses of *cognitive science* and *semiotics* to the task of understanding how visuals communicate is one of the strongest contributions not only of Colin Ware’s book (see note 33 above), but also of Alan MacEachren’s excellent book *How Maps Work – Representation, Visualization, and Design*, published by the Guilford Press (New York & London) in 1995.
35. Although its focus is principally on publicity and other ‘commercial’ applications of graphic design, a useful primer on cross-cultural communication for the ethnically diverse internal American market is the book *Designing Across Cultures* by Ronnie Lipton, published by HOW Design Books (Cincinnati, Ohio, USA) in 2002.
36. Robert E. Horn in his book *Visual Language – Global Communication for the 21st Century* (1998, MacroVU Ltd, Washington State USA) makes the claim that ‘throughout history words and images have occupied separate domains’ – a claim that is very much open to dispute – and says that diagrams which tightly integrate images and text are ‘a truly new language with the distinct syntax and semantics expected of a language’. In my opinion his dramatic claim is unjustified, but the book is an interesting study of communication using integrated text and graphics.
37. Sven Lidman is a Swedish lexicographer/encyclopaedist whose hallmark has been the use of integrated text and graphics, drawings and diagrams to accompany entries in encyclopaedias and illustrated dictionaries. He calls these visual explanations *lexivisuals* and also uses the term *verbovisual communication*. Sven Lidman is also the founder of the *Bild och Ord Akademin* (‘picture and word academy’), which in English calls itself the Swedish Academy of Verbovisual Communication – a group of about forty Swedish experts in various communication fields. See [www.boa.se](http://www.boa.se)